



Chemicals, Electronics, and Circularity –

Drivers for Decision Making

Thursday, November 3, 2022

Introductions & Background

Moderator & Panelists

➤ Moderator

- **Ben Gann** – Director, American Chemistry Council

➤ Panelists

- **Jay Illingworth** – Harmonization Director, Electronic Products Recycling Association
- **Chris Slijkhuis** – Recycling Consultant
- **Lein Tange** – Director of Sustainability, ICL Industrial Products

Agenda



01

**EPR FOR
ELECTRONICS
IN CANADA**

02

**WEEE PLASTICS
& RECYCLING
CHALLENGES**

03

**NEW TECH FOR
MORE EFFICIENT
RECYCLING**

04

**QUESTIONS &
DISCUSSION**

About NAFRA

- **ACC's North American Flame Retardant Alliance (NAFRA)**
 - Represents leading producers of flame retardants used in industrial and consumer applications
- **Engaged in public policy advocacy to promote the benefits of FRs as part of an overall approach to fire safety**
- **Members include Albemarle, LANXESS, and ICL Industrial Products**





Case Study: Safer Products for Washington

- **Department of Ecology proposing regulations for OFRs in casings and enclosures for electronic & electrical equipment**
 - Restrictions for indoor products
 - Reporting requirement for outdoor products
- **Formal regulatory proposal to be released in December 2022**
 - 45-day comment period is expected
 - Public sessions to be held in January 2023
- **Need for value chain input and engagement**
- **Contact NAFRA for more information and to coordinate**

Why are flame retardants are used in products?

- **Increased use of electronics & electrical equipment in homes and businesses**
- **Polymers/plastics enhance design & performance**
- **Changing energy sources & output of electronics – and increased use of plastics – increases fire risk**
- **End of life becoming an increasing public policy challenge for product designers**

Key Factors in FR Selection for Use in Products

Physical
Properties

Ease of
Compounding

Adequate
Thermal
Stability

Corrosivity
Issues

Compatibility

Health &
Environmental
Toxicity

Appearance

UV Stability

Electrical
Properties

Combustion
Products

Efficiency/Cost

Circularity &
End of Life



INDUSTRY-LED EPR FOR ELECTRONICS IN CANADA

*UL PROSPECTOR WEBINAR:
CHEMICALS, ELECTRONICS, AND CIRCULARITY
DRIVERS FOR DECISION MAKING
AMERICAN CHEMISTRY COUNCIL*

NOVEMBER 2022

Who Is EPRA?



- ✓ Stewards = **7,800**
- ✓ Tonnage = **1.2M tonnes**
- ✓ Collection Sites = **2,500**
- ✓ Coverage = Regulated Programs in **9** of 10 Provinces
- ✓ Public Awareness = **78%** of Canadians are aware of their local electronics recycling program.

As an award-winning, **industry-led, not-for-profit** organization, EPRA has been setting the standard **for safe, secure electronics recycling** in Canada for more than a decade.

Through our network of qualified processors, transporters and drop-off locations, EPRA provides secure and accessible recycling for consumers and businesses alike, diverting electronics from landfills.

On our journey to a **circular economy** we will share with you the progress we have made at EPRA.

Regulated Programs in Canada

Electronic Products Recycling Association operates regulated recycling programs in nine provinces across Canada. Please select your province to find out more about electronics recycling near you.



Accessibility & Awareness



Accessibility:

- **Over 2,500 authorized drop-off locations across the nation, coast to coast to coast.**
- Approximately, 97% of the Canadian population are within 30 mins (or 25 km) of an EPRA drop-off center.

Awareness:

- **Program awareness rivals most major brands. Over 78% of the Canadian population are aware of the e-recycling program in their province.**
- EPRA's mobile-friendly websites and web-based applications make it easy for residents, regardless of where they live in the country, to find out what and where they can recycle through the Recycle My Electronics network of drop-off locations.



ELECTRONICS REPRESENTS...



Figure 18: End-use markets for plastic products in Canada (kt, 2016)

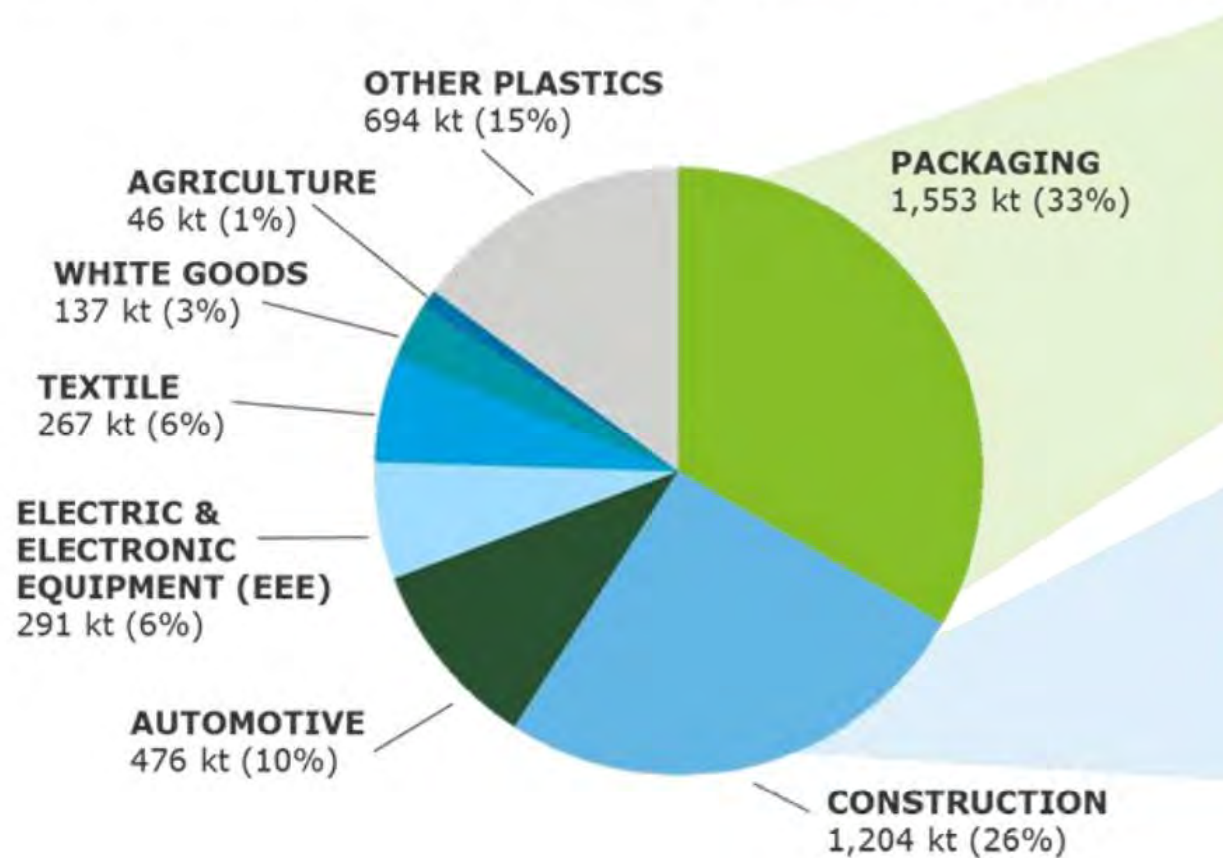

Electronics contain 360k tonnes of plastic products produced for Canadian consumption, of which 140k tonnes is discarded as plastic waste.

Electric and electronic equipment made up 6% of all plastics used in Canada and 3% of plastic waste generated

ECCC PERSPECTIVE ON EEE PLASTICS



EEE

- Half of plastics from EEE waste are targeted by a nationwide EPR system
- Value recovery rate: 15% (29% for EEE products targeted by EPR system)
- Pros: EPR system in place, wide access rate
- Cons: 33% diversion rate, low quality recycled plastics (shredded mixed material), shrinking end-market (Asia)



PLASTICS FROM EOLE A CHALLENGE



- Plastics from End-of-Life Electronics (EOLE) are continuing to be collected and processed
- Primary challenges with EOLE plastics are the number and variety of polymers in use
- Various options for EOLE plastic exist but, there is no single solution, and all are largely dependent upon primary handling and separation processes
- Some local plastics processing is already in place
- Shredded, mixed plastics are the most challenging materials to manage

PLASTICS IN PC MONITORS

The challenge of separating plastics by type:

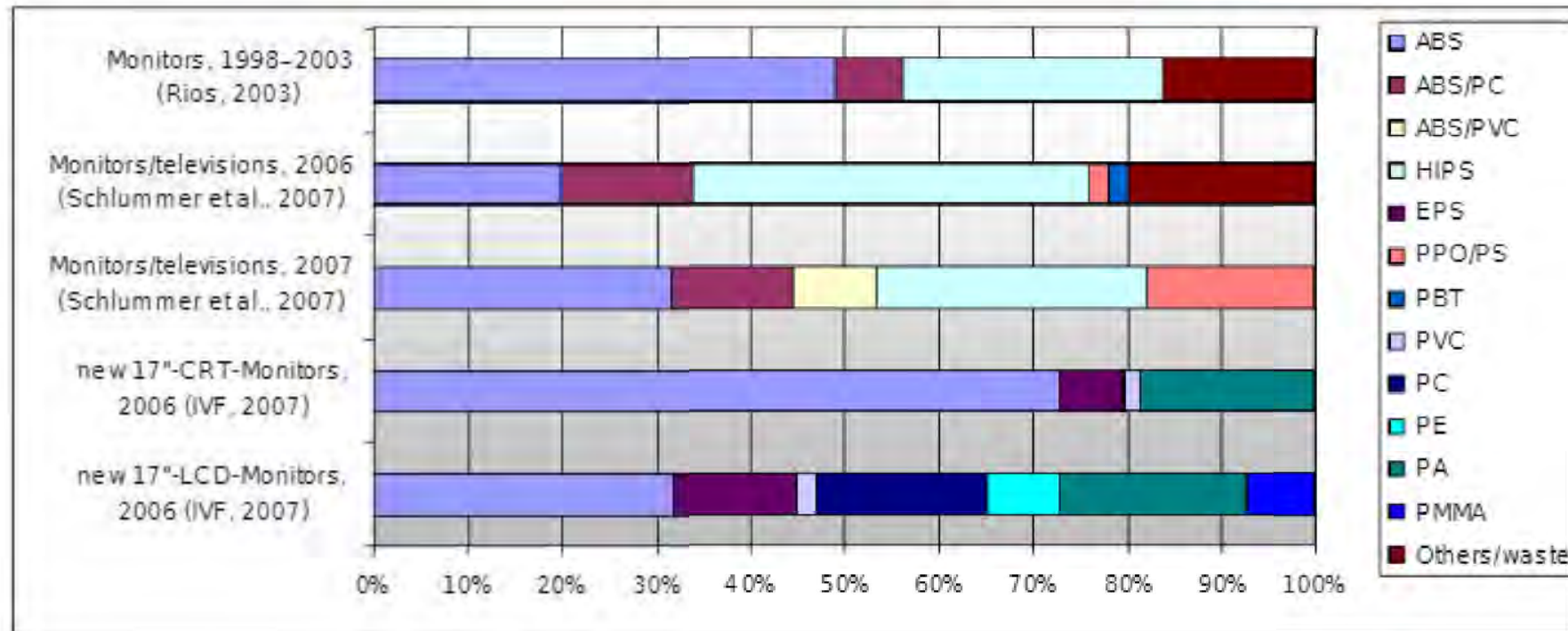

Source: *Recycling of Plastics from Waste Electrical and Electronic Equipment (WEEE) - Tentative Results of a Swiss Study*

SHREDDED PLASTICS

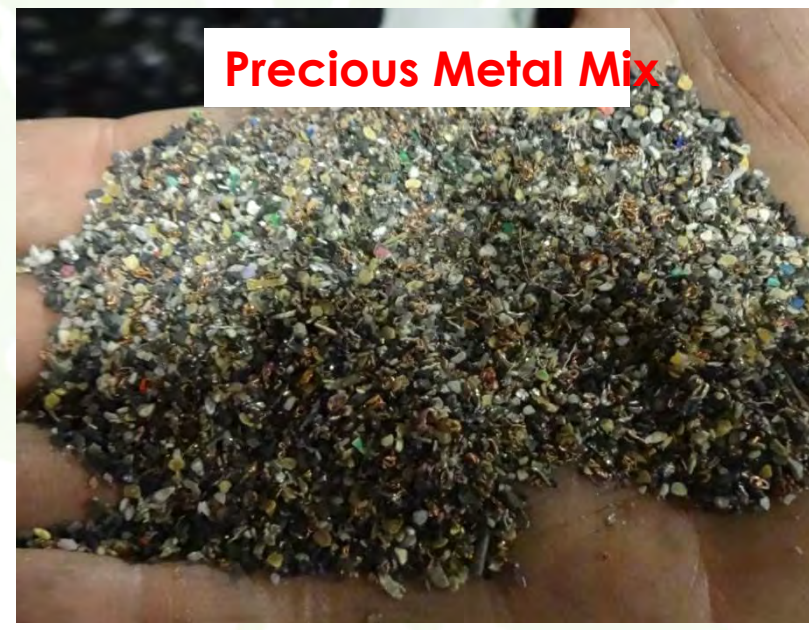

Government of Canada regulating Plastics...



As part of Canada's Zero Plastic Waste Agenda, Environment and Climate Change Canada (ECCC) is developing targets, standards and regulations to eliminate plastic waste in Canada.

In June 2022 ECCC published the Single-use Plastics Prohibition Regulations and is developing a regulation to mandate minimum recycled content for certain plastic items and to strengthen the recycling and composting of plastics through accurate labelling.

In the Fall of 2022 a discussion paper released by ECCC on the development of a proposed Federal registry which could require producers and EPR programs (among others) to report on the type of plastic products placed on the market across Canada; what happens to plastic products after the end of their useful life, including the quantity going to landfill and the quantity undergoing value recovery for new applications through reuse, remanufacture, and recycling and their import and export from Canada.

The RQO: Safe & Secure Processing



- EPRA only works with recyclers who have been verified under the national **Electronics Recycling Standard (ERS)**, which was designed by the electronics industry to ensure that EOLE are managed in a safe and environmentally-sound manner.
- The **Recycler Qualification Office (RQO)** audits the recyclers against the ERS requirements with third-party certification by the internationally recognized **R2 standard** as the first step in verification.
- EPRA requires that all recyclers actively process material and maintain appropriate environmental, health, safety and security controls for properly handling all materials. The ERS and audit processes promote:
 - * sound environmental management practices
 - * worker health and safety controls
 - * robust data security measures; and
 - * downstream processing accountability.

RQO & Plastics Processing



- The RQO have always requested to have the state of the plastic described, that detail is included on the recycler's downstream flow.
- The RQO team treats plastic as a Focus Material even though it is not defined as one under the R2 standard. This includes on-site visits for the plastic recycler to verify the processing and the outputs generated, including the disposition of those outputs.



RQO and International Processing of Plastics...



- With revisions to the Basel Convention Rules related to the transboundary movement of plastic, the RQO has changed our process to request export permits to receiving countries for plastic.
- As the US is not a signatory to the Basel Convention, the RQO will monitor and request export permits for those US companies that receive plastic and are shipping the plastic further downstream. i.e. Malaysia.
- We request the Primary Recycler who is shipping to the US, be responsible for ensuring that Canada's regulatory requirements are met



FOCUS ON A “POST-CRT WORLD”...

Electronics Evolution

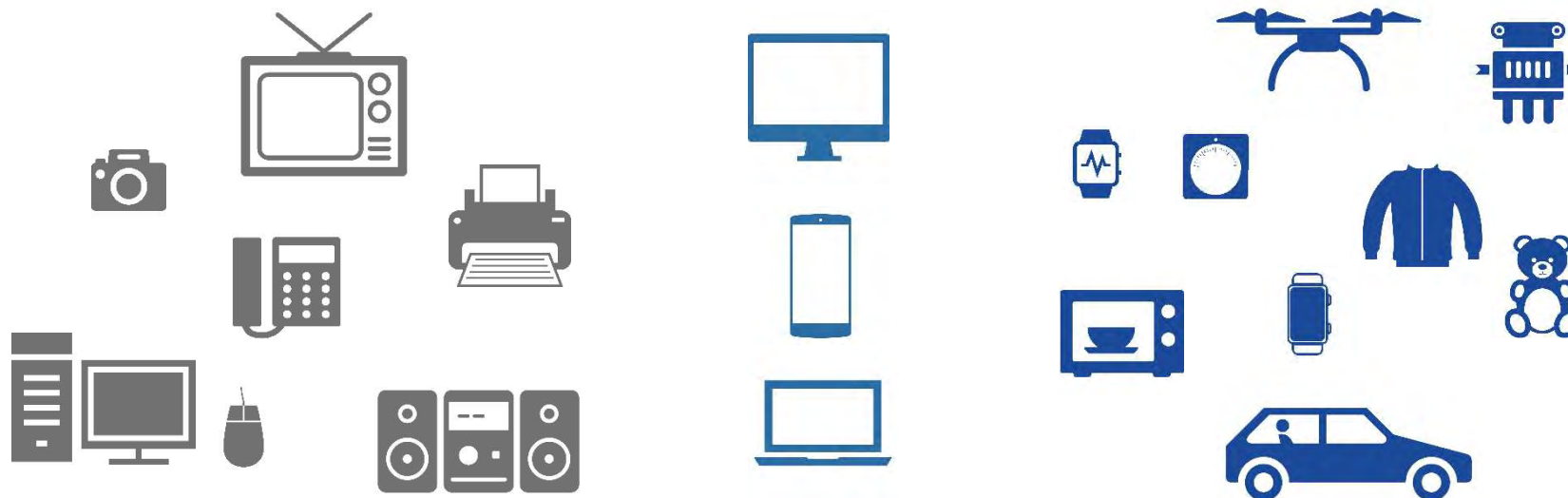

Product weight
Product size
Precious metal content

Diversity of products
Integration of components
Personally identifiable information





Jay Illingworth
Director of Harmonization

Jay@epra.ca

www.EPRA.ca

The challenges of converting the supply chain into a supply cycle for WEEE plastics



What are the challenges.....

- ▶ **The WEEE Plastics Technology Challenge**
- ▶ **The Circular Economy Canyon Challenge**
- ▶ **The POP Challenge**
- ▶ **The Waste Ever Given Challenge**
- ▶ **The Sheer Lack of Legal Harmonization Challenge**



Compliant recyclers solve environmental problems and reduce risks

What are the challenges.....

- ▶ **The WEEE Plastics Technology Challenge**
- ▶ The Circular Economy Canyon Challenge
- ▶ The POP Challenge
- ▶ The Waste Ever Given Challenge
- ▶ The Sheer Lack of Harmonization Challenge



Compliant recyclers solve environmental problems and reduce risks

Separation of plastic is difficult compared to metals



WEEE Plastics



Source: Mike Biddle, TED Talk

Plastic Recycling from WEEE

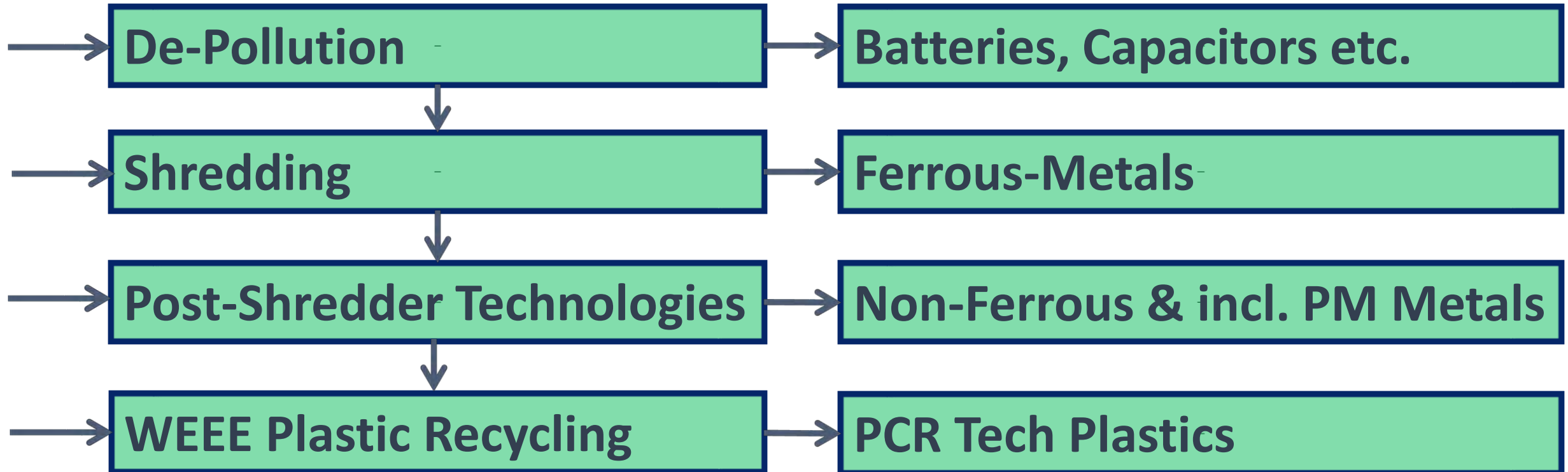

WEEE Plastics are the last remaining fraction to be treated

The concept of WEEE Plastics Recycling

► Goods-In and Pre-processing

- Each receipt is sampled and analyzed
- Material cleaned from non-plastics



The concept of WEEE Plastics Recycling

▶ Goods-In and Pre-processing

- Each receipt is sampled and analyzed
- Material cleaned from non-plastics

▶ High-tech plastic separation

- Cleaning and separations
- PP, HIPS, ABS and PC-ABS



The concept of WEEE Plastics Recycling



- ▶ **Goods-In and Pre-processing**
 - Each receipt is sampled and analyzed
 - Material cleaned from non-plastics
- ▶ **High-tech plastic separation**
 - Cleaning and separations
 - PP, HIPS, ABS and PC-ABS
- ▶ **Blending, Extrusion and Compounding**



The concept of WEEE Plastics Recycling

Waste

- ▶ **Goods-In and Pre-processing**
 - Each receipt is sampled and analyzed
 - Material cleaned from non-plastics
- ▶ **High-tech plastic separation**
 - Cleaning and separations
 - PP, HIPS, ABS and PC-ABS



Product

- ▶ **Blending, Extrusion and Compounding**
- ▶ **Lab Analyses Physical, Chemical (REACH/RoHS/POP) & Rheologic**

Output Material are PCR polymers, used as drop-in replacement for virgin

Producing sustainable PCR WEEE plastics



Procurement



- ▶ Growing supply
- ▶ Incinerated
- ▶ Self-replenishing
- ▶ Sustainable



Processing



- ▶ Mechanical 'mining' process
- ▶ Innovative technologies
- ▶ < 10% of energy
- ▶ Save about 3-4 tons CO₂/ton



Selling



- ▶ "Green" products
- ▶ Virgin-like quality possible
- ▶ More sustainable business
- ▶ PCR plastics



And these are just some examples of products with 100% PCR Plastics



Post-Consumer Recycled WEEE Plastics (PCR Plastics)

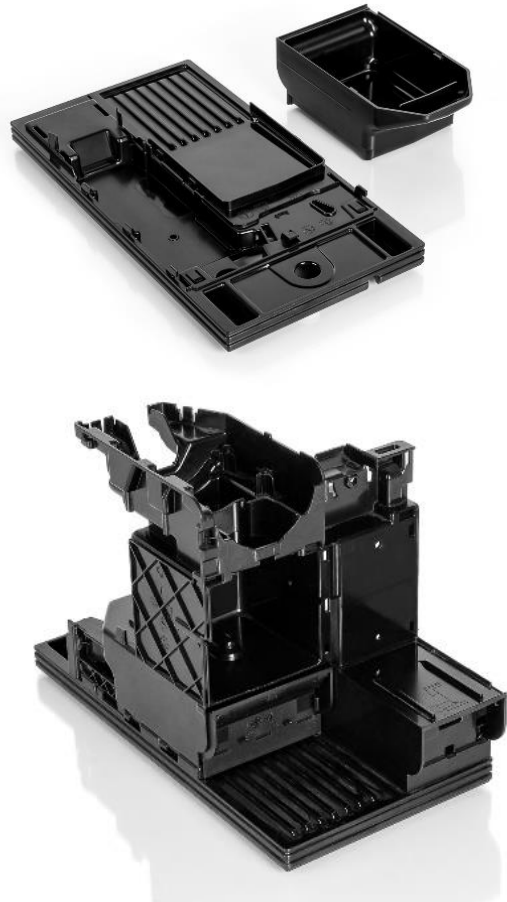

Deutsche Telekom
Speed Home WLAN

Automotive, Electrical or Electronic
Product

www.prseventeurope.com



What are the challenges.....

- ▶ The WEEE Plastics Technology Challenge
- ▶ **The Circular Economy Canyon Challenge**
- ▶ The POP Challenge
- ▶ The Waste Ever Given Challenge
- ▶ The Sheer Lack of Harmonization Challenge



Compliant recyclers solve environmental problems and reduce risks



A recyclers' view on policy development.....



The "Circular Economy" side

The "Non-Toxic" side

Recycler

Closing the missing link in the Circular Economy



Closing the missing link in the Circular Economy

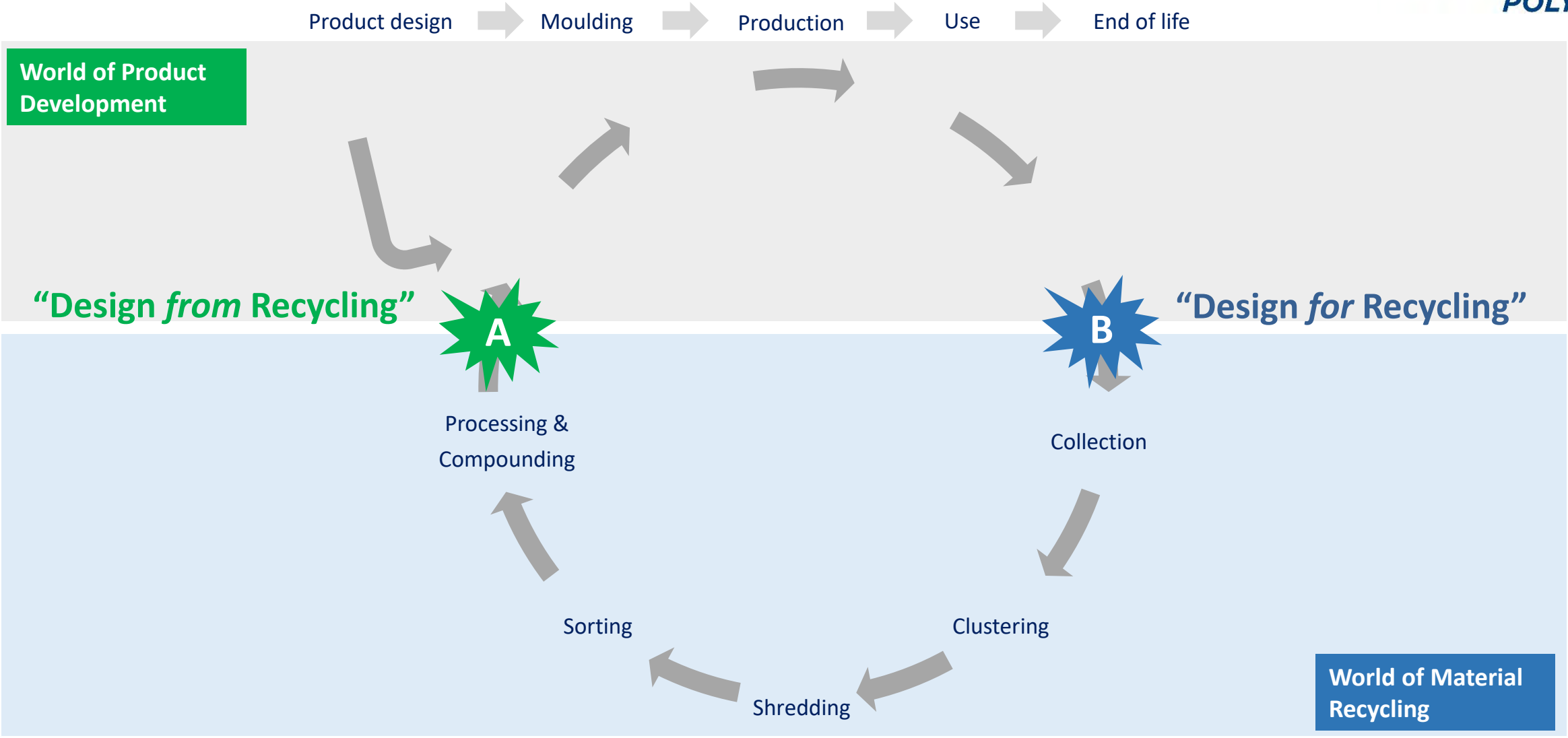

Book-Recommendation: [Design from and for Recycling \(Poly-CE\)](#)

What are the challenges.....

- ▶ The WEEE Plastics Technology Challenge
- ▶ The Circular Economy Canyon Challenge
- ▶ **The POP Challenge**
- ▶ The Waste Ever Given Challenge
- ▶ The Sheer Lack of Harmonization Challenge



Compliant recyclers solve environmental problems and reduce risks

Legislation overview Brominated Flame Retardants



EEE Products

IT electronics

(microprocessors, computer servers, modems, printers, copy machines...)

Consumer electronics

(hair dryers, heaters, TV sets, laptops...)

White goods

(tumble dryers, dishwashers, washing machines...)

Legislation overview Brominated Flame Retardants



EEE Products

Plastic Parts

IT electronics
(microprocessors, computer servers, modems, printers, copy machines...)

Consumer electronics
(hair dryers, heaters, TV sets, laptops...)

White goods
(tumble dryers, dishwashers, washing machines...)



Housing

Printed circuit boards

Cables

Connectors

Legislation overview Brominated Flame Retardants



EEE Products

IT electronics
(microprocessors, computer servers, modems, printers, copy machines...)

Consumer electronics
(hair dryers, heaters, TV sets, laptops...)

White goods
(tumble dryers, dishwashers, washing machines...)

Plastic Parts

Housing

Printed circuit boards

Cables

Connectors

- HBCD
- DecaBDE³
- c-PentaBDE
- c-OctaBDE
- BDP
- RDP
- TBBPA
- DOPO
- EBP
- ATH
- MDH
- ATO
- Br'd PS
- Mel.Cyanurate

Legislation overview Brominated Flame Retardants

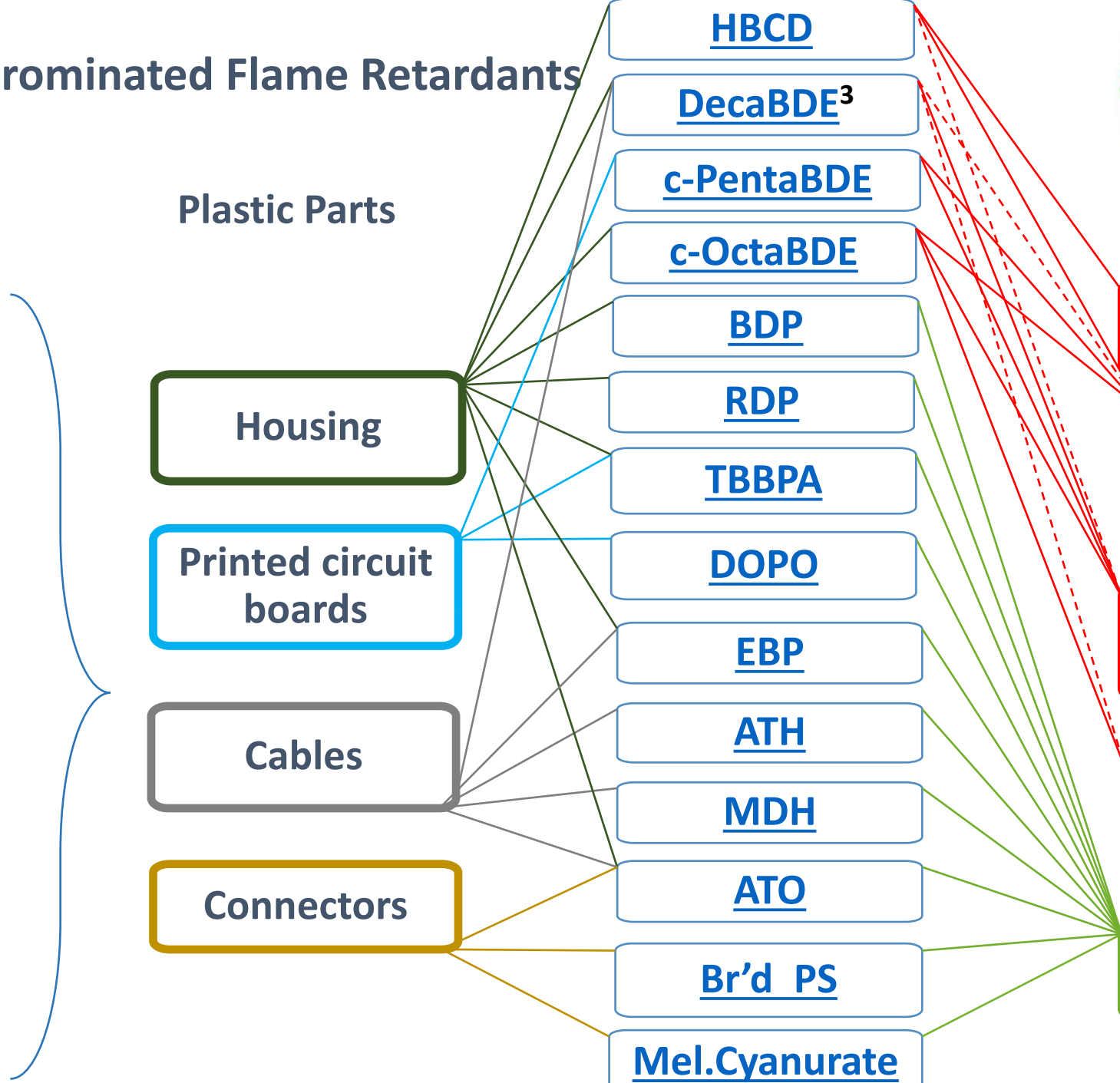
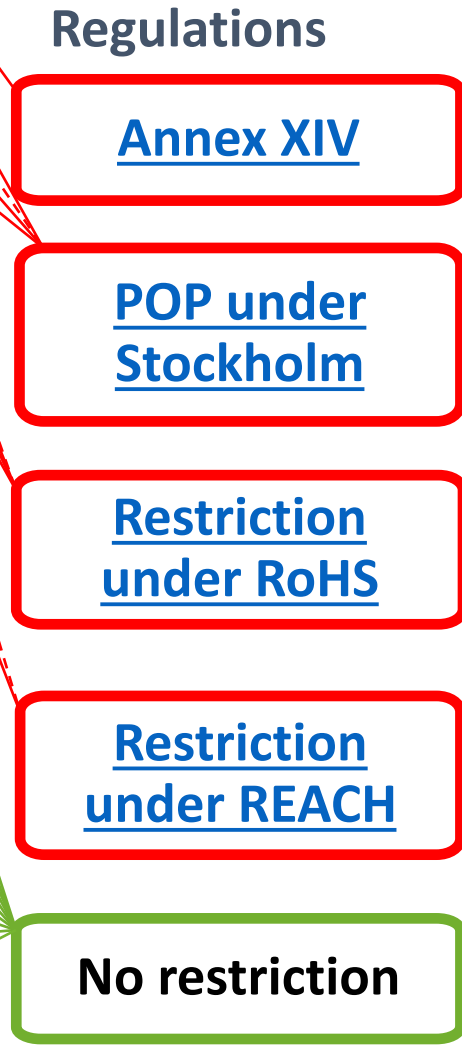
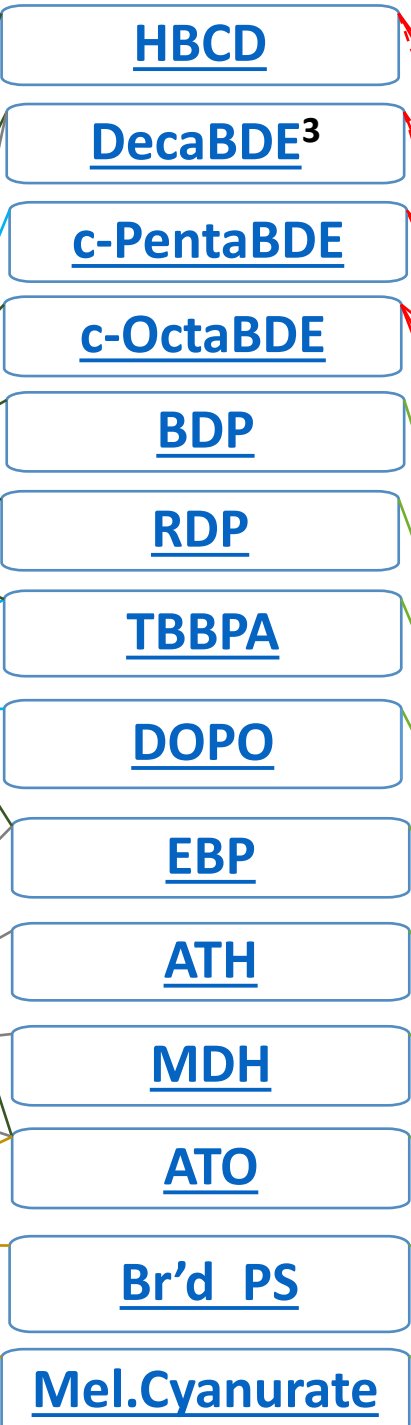
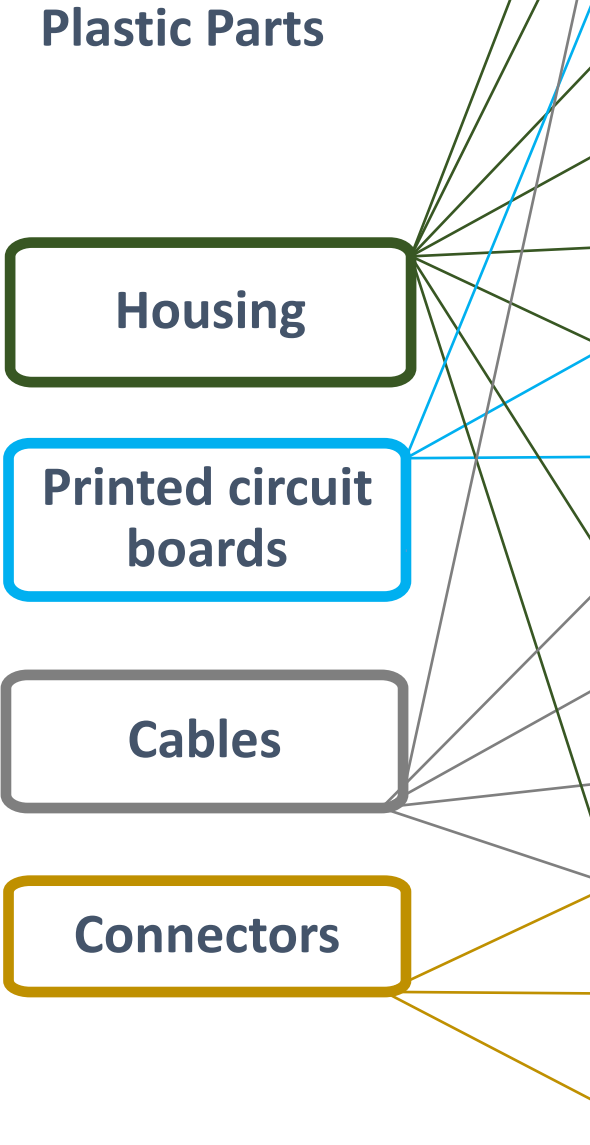
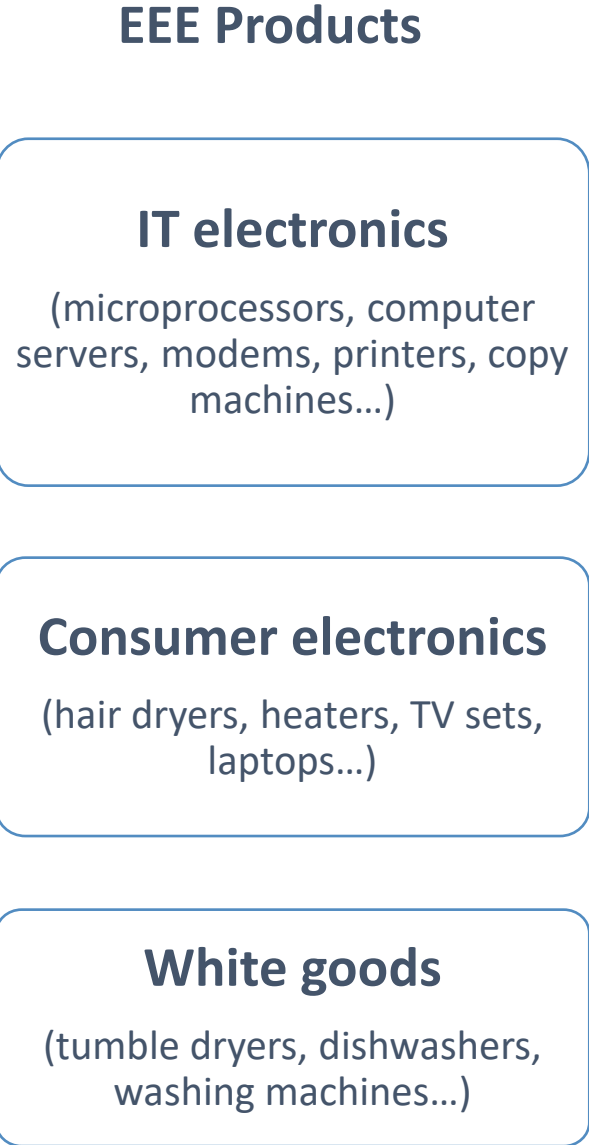

WEEE Plastics Mass Flows (EU28+2, 2020)

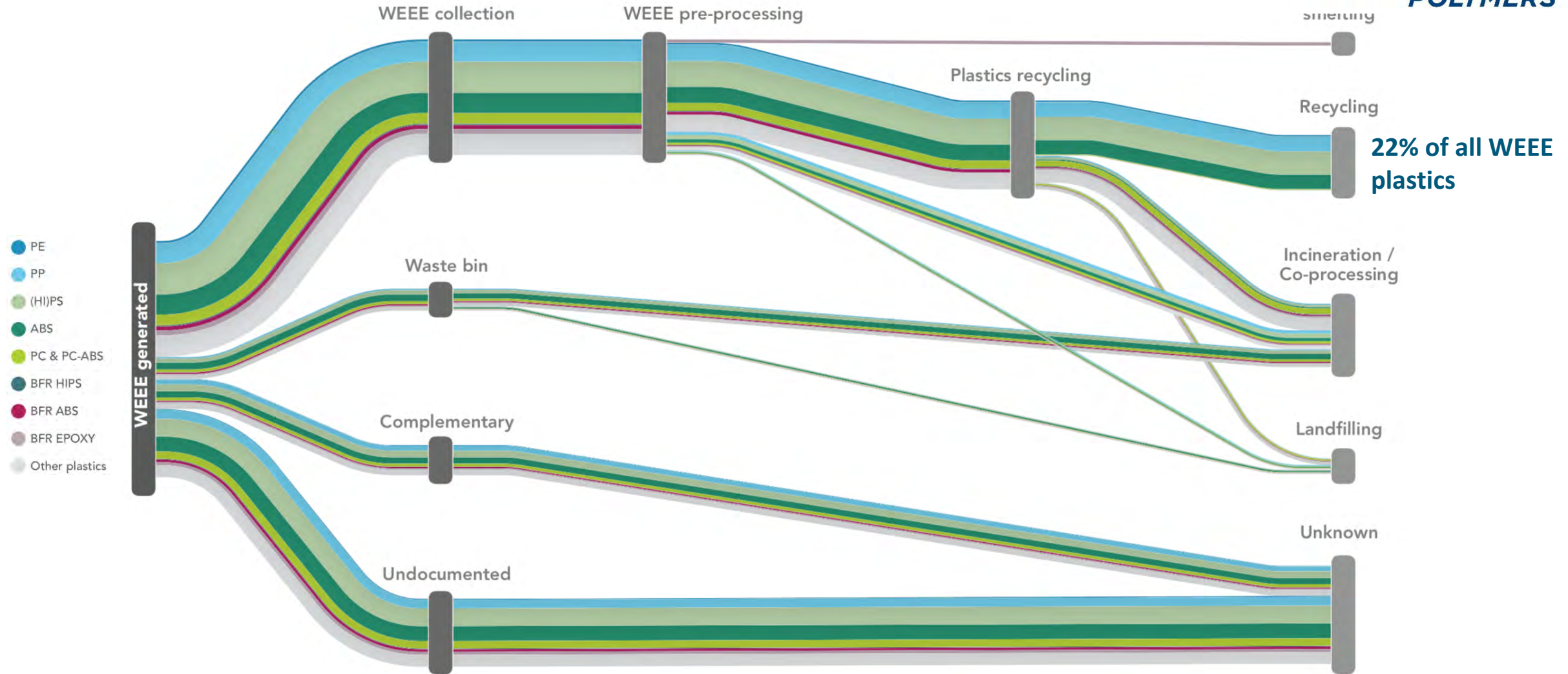

BFR plastics mass flows (EU28+2, 2020)

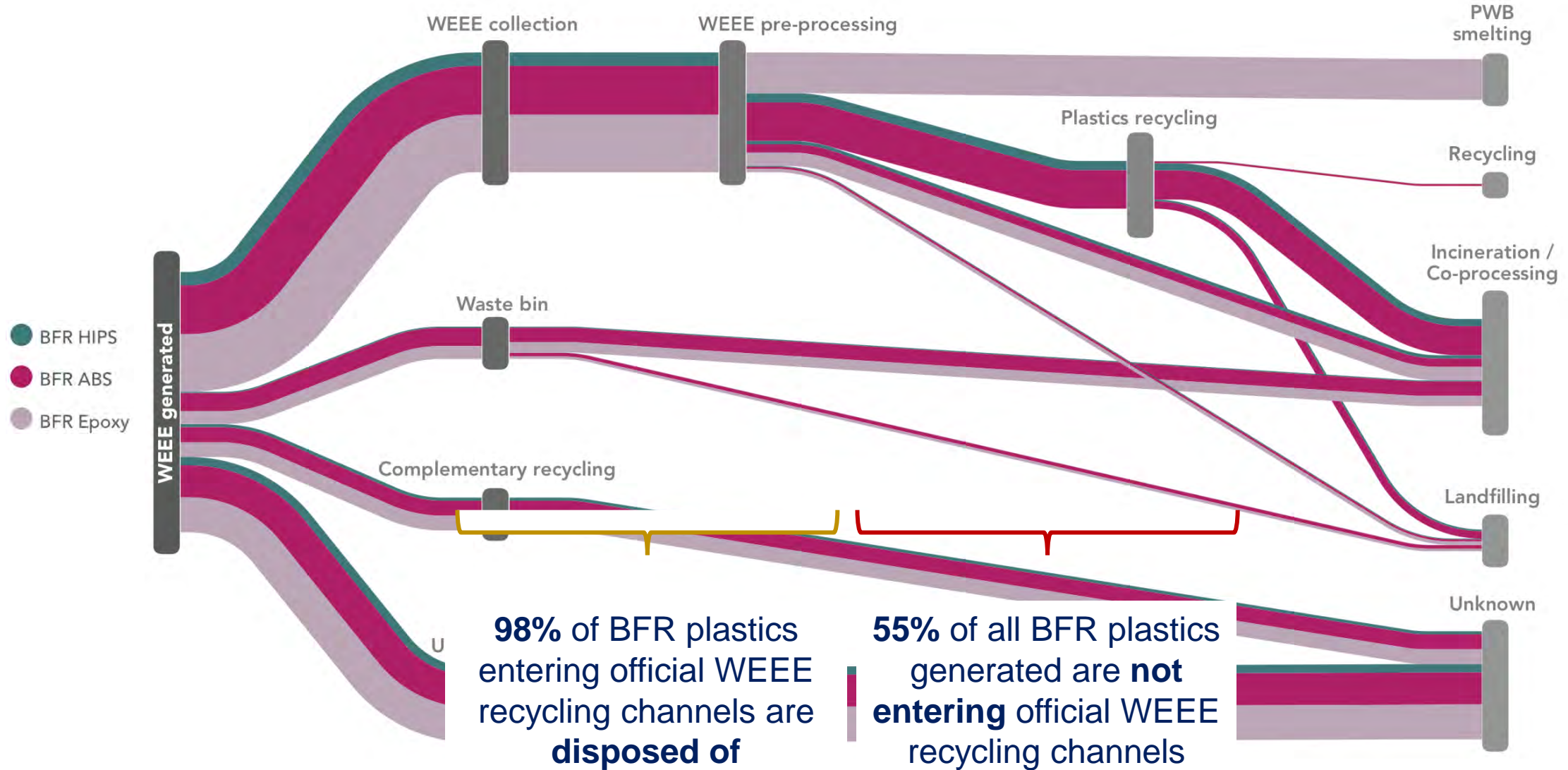

Impacts of continuous discussions about BFRs

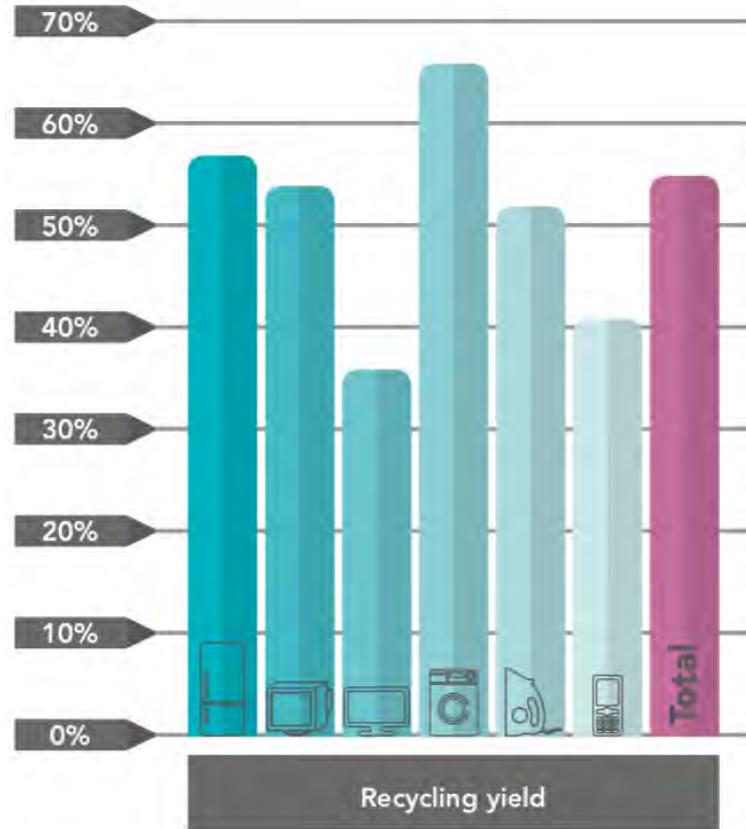

recycled plastics output /
input to plastic recycling process

Source: [SOFIES Study](#)

Share of target polymers

- ▶ Mainly PP, PE, ABS, PS and PC-ABS – averages some 50 %
- ▶ Can be **separated**

Lacking reliable validated screening techniques

- ▶ Reducing already low thresholds are an **existential problem**
- ▶ These **cannot be reliably screened** with existing XRF methods
- ▶ EEE products need a **risk and not a hazard approach**

Continuous and complex discussions

- ▶ This debate about thresholds runs **over 15 years**.
- ▶ **POP BFRs** today only represent **15% of the BFR charged plastics**
- ▶ Cycle: **Stockholm, Basel, POP Regulation, REACH, RoHS, WEEE**
- ▶ We need a **One-Substance – One Assessment** logic

What are the challenges.....

- ▶ The WEEE Plastics Technology Challenge
- ▶ The Circular Economy Canyon Challenge
- ▶ The POP Challenge
- ▶ **The Waste Ever Given Challenge**
- ▶ The Sheer Lack of Harmonization Challenge



Compliant recyclers solve environmental problems and reduce risks

A Never Given fact was given by the Ever Given.....

...as it wedged the Suez Canal for 6 days and it was major global news for this amount of time and beyond.

Do you know that this is happening day-in-day out with waste?

The plastics recycling industry is facing more and more bans on shipments and all mixed WEEE plastics need notifications.

If Europe is serious about the Circular Economy, this needs to be changed urgently – shipments of plastic waste to compliant recyclers must be quicker and easier.

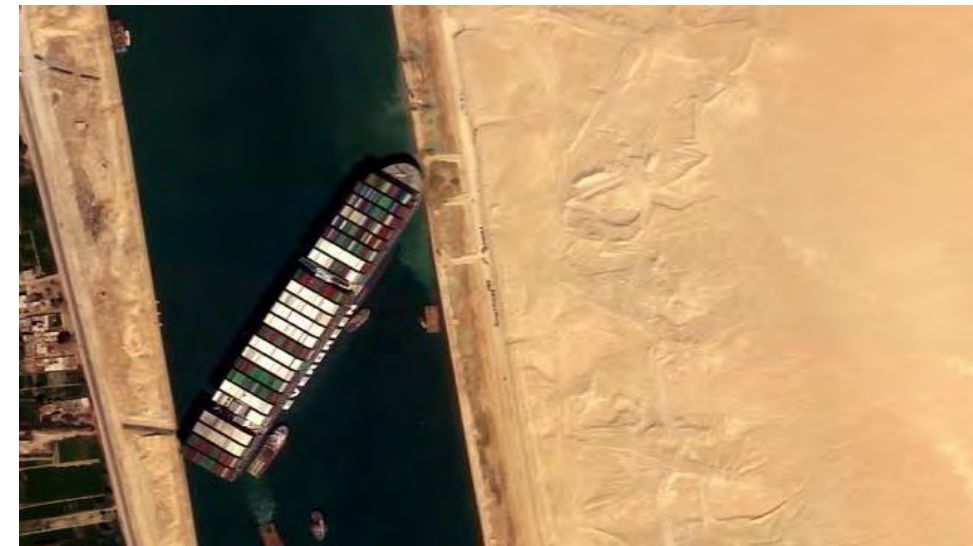

We call it the "big waiting".....

- ▶ Huge files are involved
- ▶ Many authorities still need original signatures
- ▶ Files are sent to all authorities involved
- ▶ No harmonized rules and procedures
- ▶ Interpretations can differ per country/region
- ▶ It is linked to major costs
- ▶ But most importantly.....with huge delays



One notification took us over 4 years..... How can a circular economy develop this way?

The EU needs Fast-Track Notifications

- ▶ Much simpler and harmonized business processes and waste classifications are needed
- ▶ Compliant and environmentally sound recyclers should be able to be authorized to take in defined wastes
- ▶ And "green lanes" or "fast-tracks" should be created for these flows, at least within the EU



We should be able to work at the pace of business and not at the pace of administration

What are the challenges.....

- ▶ The WEEE Plastics Technology Challenge
- ▶ The Circular Economy Canyon Challenge
- ▶ The POP Challenge
- ▶ The Waste Ever Given Challenge
- ▶ **The Sheer Lack of Harmonization Challenge**



Compliant recyclers solve environmental problems and reduce risks

Circular economy and harmonization

- ▶ Often requires measurements of SOC's
- ▶ There is an inflation of classifications as hazardous
- ▶ Recycling technologies developed to remove SOC's
- ▶ Recycling facilities may not take in hazardous waste
- ▶ Simpler and harmonized rules are needed



Circular economy and harmonization

- ▶ Recycled resources re-enter Circular Economy
- ▶ Need to comply with product legislation (REACH)
- ▶ Here is where the analyses should take place
- ▶ And this should be based upon harmonized rules

- ▶ Often requires measurements of SOC's
- ▶ There is an inflation of classifications as hazardous
- ▶ Recycling technologies developed to remove SOC's
- ▶ Recycling facilities may not take in hazardous waste
- ▶ Simpler and harmonized rules are needed



Let's please strike the right and intelligent balance.....

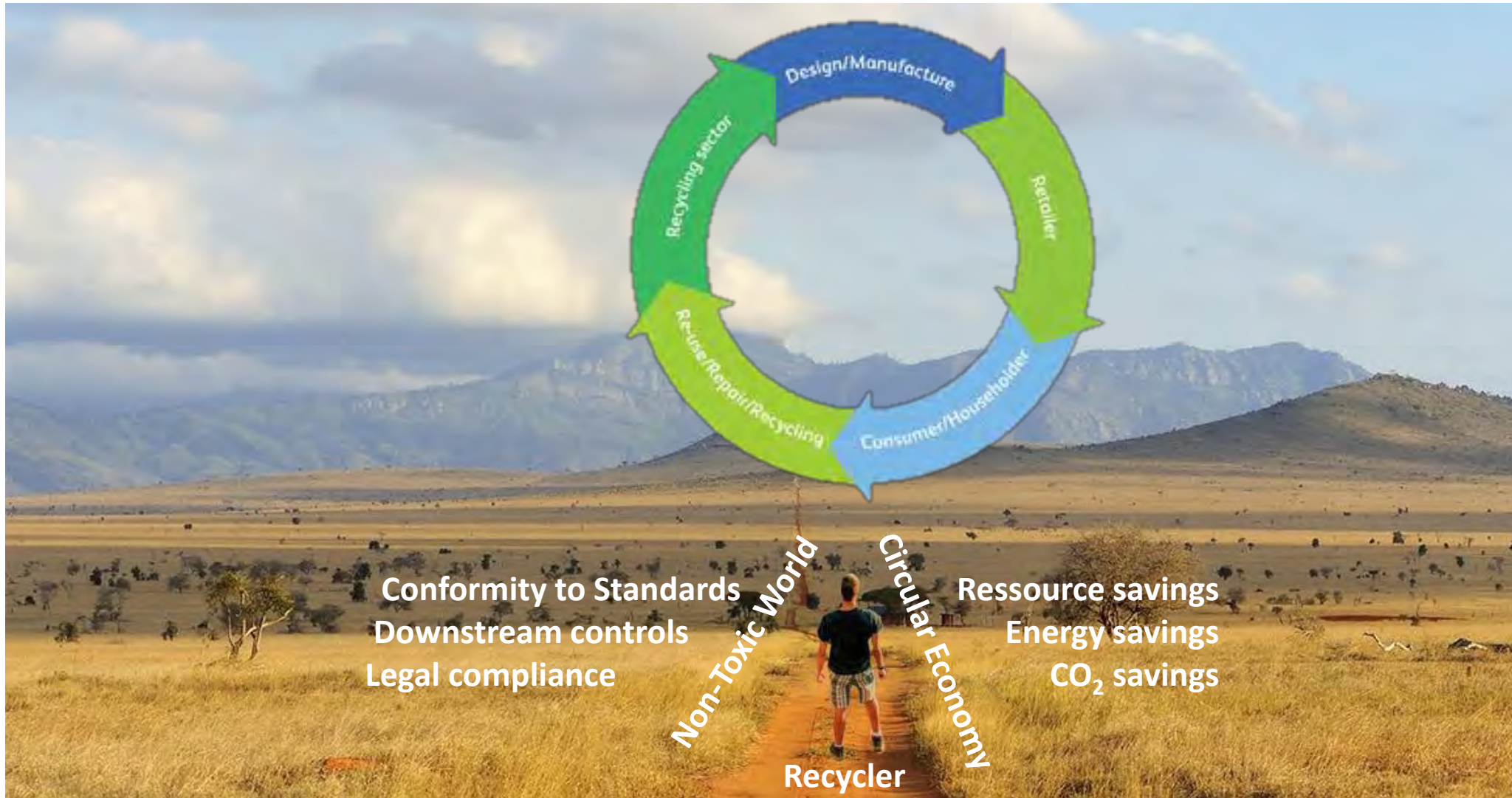

between “Non-Toxic” and “Circular Economy” objectives

THANK YOU

GRACIAS
ARIGATO
SHUKURIA
JUSPAXAR
DANKSCHEEN
TASHAKKUR ATU
YAQHANYELAY
SUKSAMA
EKHMET
MEHRBANI
PALDIES
BOLZİN
MERCİ
TINGKI
BİYAN
SHUKRIA
MIMONCHAR

SPASSIBO
SNACHALHYA
NUHUN
CHALTU
WAHABEJA
MAITEKA
YUSPAGARATAM
HUI
GAI
HATUR
EKOJU
SIKONO
MAKETAI
MERASTAWHY
GAEJTHO
AGUYJE
FAKAAUE
SAINCO
KOMAPSUMNIDA
MAAKE
LAH
UNALCHEESH
DENKAUJA
NENACHALHYA
MERSI
SPASIBO
MIMONCHAR



Flame Retardant plastics are circular: Novel technologies enabling efficient recycling

Lein Tange
Sustainability Director
ICL-IP

Chemicals, Electronics, and Circularity – Drivers for Decision Making

November 3rd, 2022



About ICL Group



\$7.0 bn sales in 2021



Global manufacturer of bromine, fertilizer and specialty chemicals



~13,000 Employees



20 R&D centers with 500 researchers



Multiple awards for sustainability efforts, inclusion in FTSE4Good and A- Carbon Score





About BSEF

- BSEF – the International Bromine Council, is the global representative body for bromine producers and producers of bromine technologies
- Founded in 1997, BSEF works to foster knowledge on the societal benefits of bromine and its applications
- The members of BSEF are Albemarle Corporation, ICL Industrial Products, Lanxess and Tosoh
- Offices & representatives in Europe, China, Japan, India, Brazil, Canada
- Affiliate member of the European Chemicals Council; member UNEP Hg Partnership; member European Association for Energy Storage

www.bsef.org

 [@BromineInfo](https://twitter.com/BromineInfo)





Why fire safety is important

Changing demographics – an aging and more vulnerable population

- 5,000 fire deaths in the EU every year (EUROFSA, 2020)
- 50,000 fire induced injuries, according to conservative estimates.
- Special attention needs to be paid to Europe's **growing vulnerable community** (in 2020, over 20% of the EU's population was aged 65 or over, Eurostat)

Dangerous reduction in escape times

- Changes in the material composition, higher combustible content in rooms
- Wider range of products in people's homes (smart devices and homes etc.)
- Trend towards more airtight homes for energy efficiency

A fire is a traumatic experience and wastes materials

- Human tragedy, fatalities, burn injuries
- Financial and psychological damage
- Materials are damaged, contents are lost, water is wasted, and pollutants are released into the environment

End of Life options for waste plastics

End-of-life management & emissions scenarios

- Reuse of plastics / recover of metal,
- Physical recycling to recover polymer/additives
 - Mechanical recycling
 - Solvent based purification process
- Chemical recycling:
(de-polymerisation/pyrolysis)
- Incineration – energy recovery
- Landfill – least favored



Challenges ahead for plastics with SVHC/POP's:

- POP regulation lowering SVHC/POP concentrations preventing normal plastics recycling
- RoHS/REACH (end of waste => 'new' products) - SVHCs < 1000 ppm
- Uncertainty in technologies being part or NOT part of the recycling quota preventing investors to start up innovative technologies

But relevant to all plastics within heavy (ABS-BFRs) sorted fraction:

- Sorting black plastics
- Concentrating the plastics to a purity of > 95%
- Quality of recyclate
- Proof of product being compliant with REACH and POP regulation
- Analytical proof of POPs/ and SVHC is extremely challenging due to lack of standardized global approved analytical methods
- Scale of Economy



Example recycling process of waste plastics from E&E plus ASR (Electrical & Electronic Equipment plus Automotive Shredder Residue)

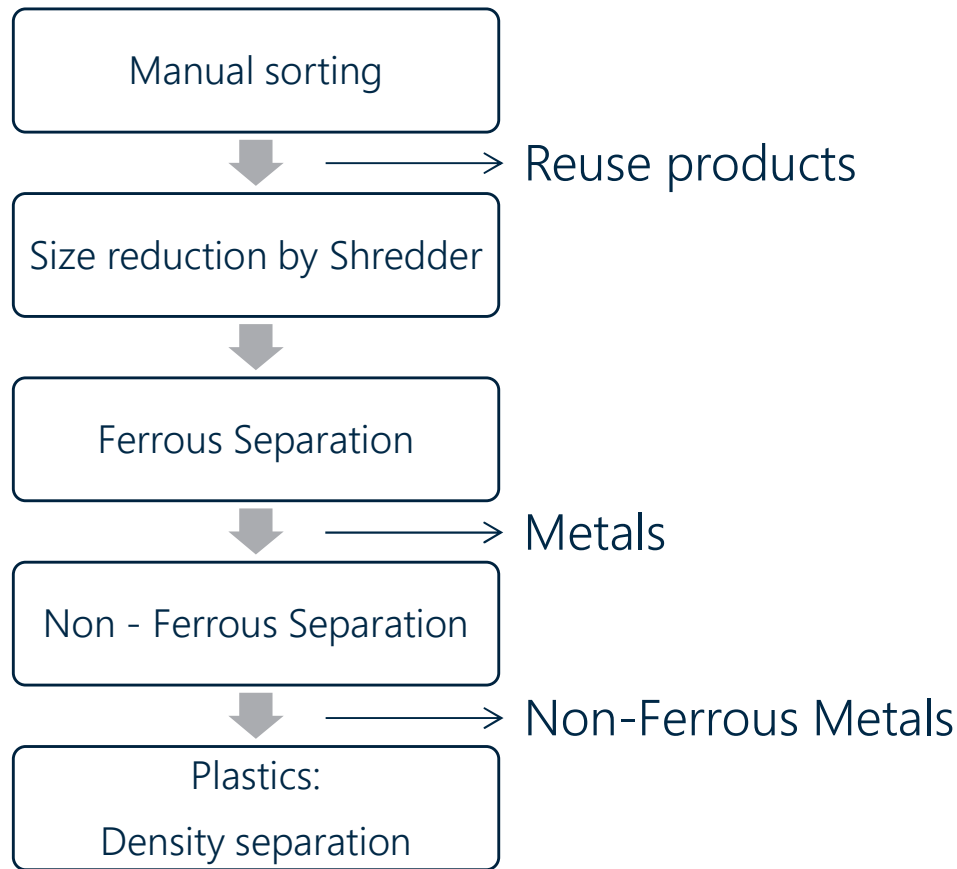

After sorting → Solvent based purification process

→ Lightweight plastics: PE, PP, PS, HIPS, ABS

→ Heavy plastics: HIPS FR's plus ATO, ABS FR's, PC, PVC, PA, ...

→ Mechanical recycling

→ Incineration or Landfill



Solvent based purification process for possible scaling up to demoplant 3KT of ABS

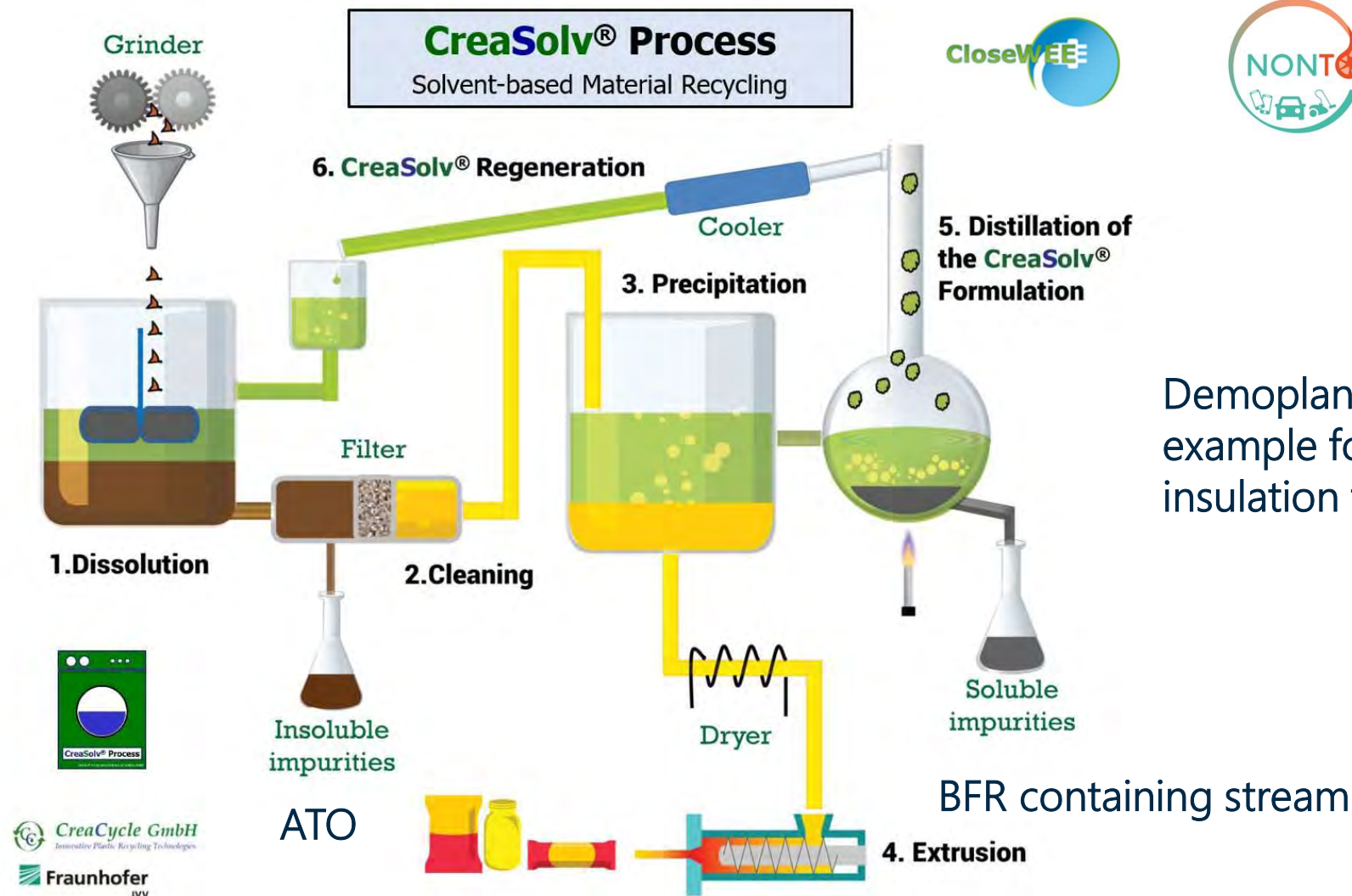

Demoplant PSLoop as example for scaling up: EPS insulation foam with HBCD

CreaSolv® is a registered trademark of CreaCycle GmbH



Plastics from E&E and ELV closing the loops

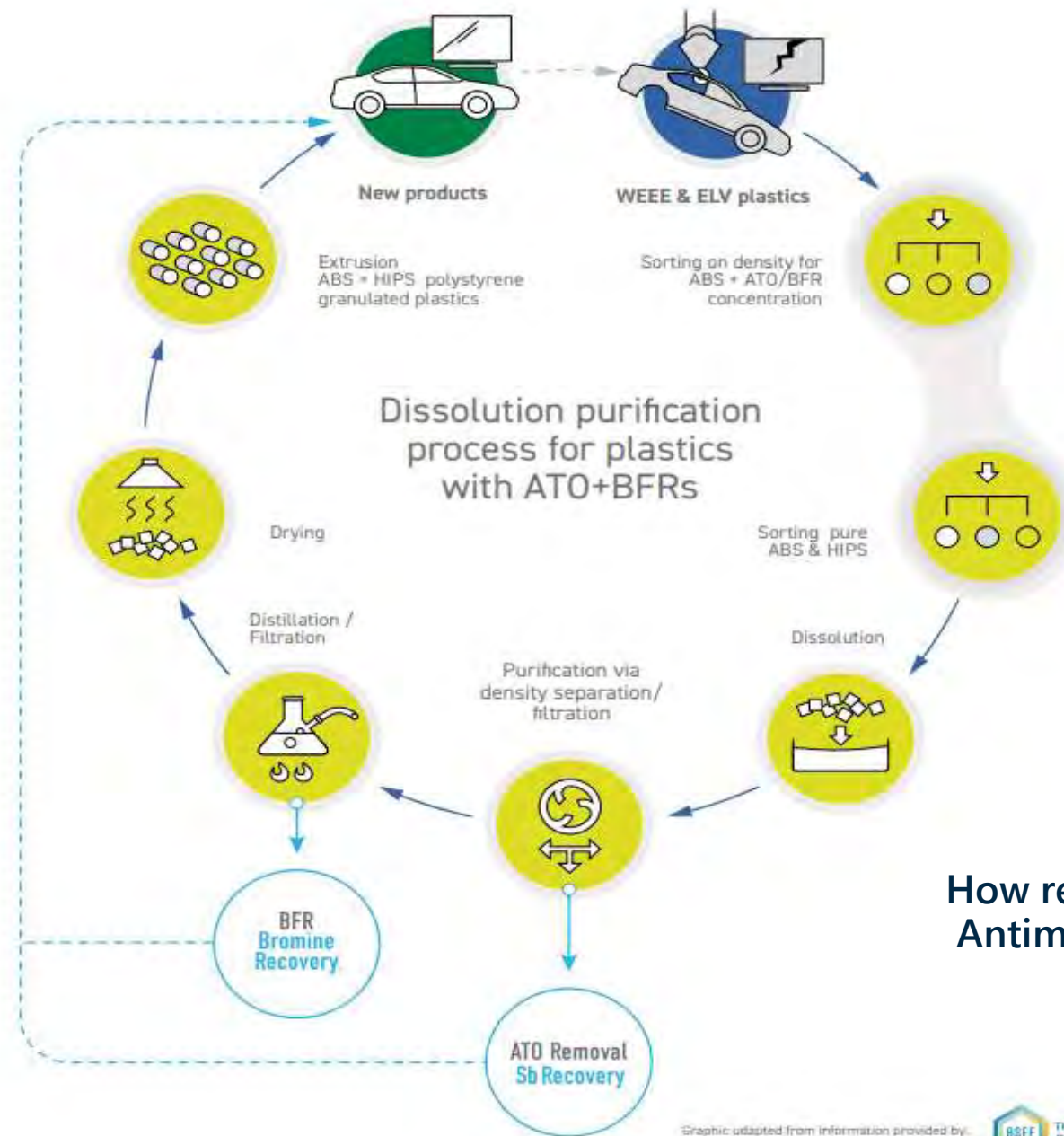

How recyclable is plastics with Bromine and Antimony and how do we close the loops?



Chemical Recycling containing BFRs:

Processing difficult to handle mixed plastics waste streams with “less sorting” efforts → chemical recycling can be a valuable option

- Styrenics plastics for depolymerization into styrene monomer handling EPS with HBCD (Agilyx)
- R&D studies on different levels handling plastics containing BFRs via pyrolysis using catalysts and acid scavengers
- Charles Darwin University work on Pyrolysis – catalysts and additives research to enhance hydrocarbon, bromine and antimony recovery
- Super critical CO₂ for extracting BFRs out of the plastics (CreaTor-NONTOX)
- Push to include CR in Europe as “transitional” CE option



Conclusions:

- ✓ Challenges for mechanical recycling due to scale of economy, sorting identification and quality (also SVHCs/ POPs contaminants)
- ✓ Innovative technologies can be used for plastics with BFRs/ATO
- ✓ Need for predictable and stable legislation (UTC-LPLC-REACH-standards)
- ✓ Solvent based dissolution technologies are emerging and ready for scale up especially for the “heavy” plastics fraction (ABS) containing BFRs/ATO
- ✓ Scaling up R&D/Pilot into a demoplant takes years → 2024-2028 NPPR Netherlands
- ✓ Teamwork of recyclers, BFR producers (ICL) and ATO producers (Campine), is needed
- ✓ Chemical Recycling for difficult to handle plastics is becoming a more relevant process





Thank You

Lein Tange – Sustainability Director ICL-IP.

Lein.Tange@icl-group.com

www.icl-ip.com/flame-retardants/



Key Takeaways

Key Takeaways

- **Recycling landscape is complex & evolving**
- **Increasing interest from regulatory authorities**
- **New technologies are emerging that may increase options and possibilities for circularity**
- **Public policy challenges require product manufacturers to be informed and weigh-in where appropriate**

Questions & Discussion



Thank You for
Attending

